

CDT-30B
Soil Moisture & Temperature & EC Sensor
Manual

Catalogue

Product Brief.....	1
Application	1
Features	1
Technical Parameters	2
Product Size	3
Accessories:	3
MODBUS RTU Communication Protocol (Apply to CDT-30B product)	4
1.1 CRC Description:	4
1.2 Return Error Code Rule:	4
1.3 Standard MODBUS register description	4
1.4 Electrical Connections	5
1.5 Communication Example	5
Other Weather Sensors	7



CDT-30B Soil Moisture & Temperature & EC Sensor

◆ Product Brief

CDT-30B Soil Moisture, Temperature & EC Sensor is integrated the moisture, temperature & EC measurement. The stainless steel probe is inserted into soil surface or soil profile to test quickly. The product with temperature compensation to ensure the accuracy of measurement. The probe can be permanently embedded underground and be connected to a data logger for unlimited testing.

◆ Application

- Meteorological Monitoring
- Micro Environmental Monitoring
- Grid Environment Monitoring
- Agricultural Meteorological Monitoring
- Meteorological Traffic Monitoring
- Photovoltaic Environment Monitoring
- Meteorological Environment Monitoring for Smart Cities

◆ Features

- Small in size
- High integration
- Easy to install
- Free testing software MODBUS - poll V1.0 (ask your salesperson for it)
- Integrated design
- Low starting threshold
- One year warranty

Technical Data

CDT-30B Soil Moisture & Temperature & EC Sensor

◆ Technical Parameters

Parameters	Measuring Range	Accuracy	Resolution
Moisture	0-100% (m ³ /m ³)	±2%(0-50%) ±3%(51-100%)	0.1PH
Temperature	-30°C-+70°C	±0.3°C	0.1°C
EC	0-10mS/cm 0-20mS/cm	±3%FS	0.001uS/cm
Principle	FDR		
Supply	5VDC,12-24VDC (power consumption<0.2W)		
Response time	<3s (soil moisture>30%)		
Housing	ABS		
Dimensions	71*45*16mm(probe:2* Ø3*55mm,1*Ø4*55mm)		
Operating Temperature	-40°C-+80°C		
Ingress Protection	IP68		
Storage	10-60°C@20%-90%RH		
Probe material	316L stainless steel		
Effective measurement area	With the center of the probe diameter is 70mm, high 70mm cylinder		

★ Specifications may be updated without prior notice.

◆ Product Size

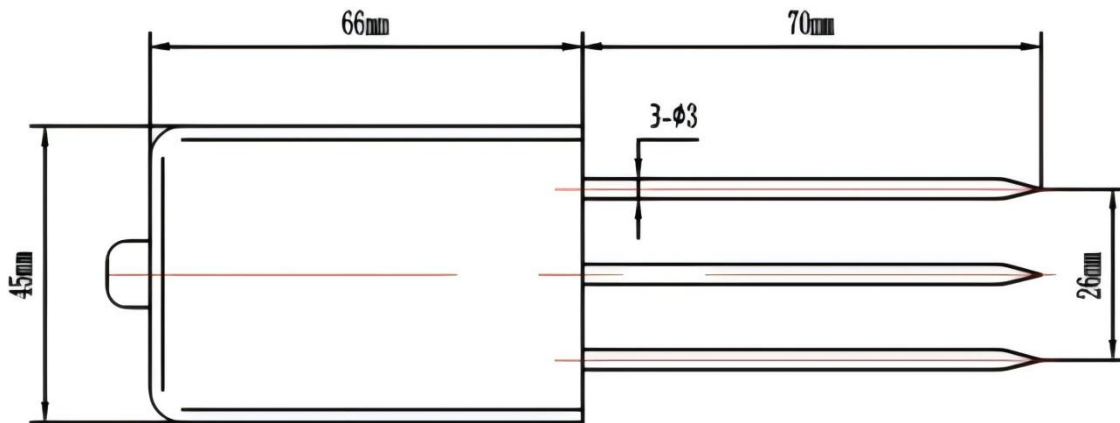

◆ Accessories:

Mounting Manner:



Soil Surface measure method

1. Select a representative soil environment to clean up surface debris and vegetation
2. Insert the sensor vertically and completely into the soil
3. If there is a hard object, the measurement location should be replaced and re-measured
4. For accurate data, it is recommended to measure multiple times and take the average

MODBUS RTU Communication Protocol

(Apply to CDT-30B product)

Baud Rate: 9600

Data Bits: 8

Stop Bit: 1

Check Bit: None

1.1 CRC Description:

Among all the following instructions, the two bytes of CRC16 in MODBUS RTU protocol are as follows: the low byte comes before and the high byte comes after.

In the following instructions, the assumed sensor address is 0x01 (the default sensor address is 01).

1.2 Return Error Code Rule:

When receive error instruction (including CRC16 validation error), no error codes will be returned. It is considered to be a failure, when there is no return data in 200ms after the instruction is issued. Upper computer may resend instruction.

1.3 Standard MODBUS register description

Special Notice:

The quantity or length of the register in MODBUS is two bytes with 16 bits as a unit (the high byte comes first, and the low bytes follows), instead of one byte with 8 bits as a unit.

User shall ensure that the address and quantity of register in command are confined within the range specified by the system. Otherwise, the output of the sensor will be unpredictable. Users shall ensure that the MODBUS command complies with the requirements of this manual in the software design of the upper computer and the minimum query period supported is 1s/ time.

Input register: read with function code 03

Address	Operation	Contents	Note
0x0000	Read-only	Temperature, a hexadecimal number magnified by 10 times. For example, 0x0116 indicates 278/10=27.8°C	
0x0001	Read-only	Moisture , a hexadecimal number magnified by 10 times. For example, 0x03E8 indicates 1000/10=100%	
0x0002	Read-only	EC , a hexadecimal number magnified by 1000 times. For example, 0x0DEB indicates 3565/1000=3.565mS/cm	
0x0030	Read/Write	Device Address(1-255)	Default address 01

1.4 Electrical Connections

Connector (cable)	Voltage/Current	RS485
Red	V+	V+
Black	V-	V-
Yellow	/	RS485A
Green / Blue	/	RS485B

1.5 Communication Example

The following is an example of how to use MODBUS RTU commands to access system registers:

1. Read multiple input registers (real time data) command

Send: 01 03 00 00 00 03 05 CB

03	03	00 00	00 03	05 CB
System Address	Function Code	Register Address	Number of Registers	CRC16 check digit automatically generated by software

CTDA Technical Data

CDT-30B Soil Moisture & Temperature & EC Sensor

Answer: 01 03 06 01 16 03 E8 0D EB AD C8

01	03	06	01 16 03 E8 0D EB	AD C8
System Address	Function Code	The number of bytes in a data segment	Segment Data	CRC16 check bit

Analytical Data:

$$0x0116 = 0x01 * 256 + 0x16 = 278$$

$$\text{Temperature} = 278/10 = 27.8^{\circ}\text{C}$$

$$0x03E8 = 0x03 * 256 + 0xE8 = 1000$$

$$\text{Moisture} = 1000/10 = 100\%$$

$$0x0DEB = 0x0D * 256 + 0xEB = 3565$$

$$\text{Moisture} = 3565/1000 = 3.565\text{mS/cm}$$

2. Modify internal register (system address) command (change the address to 0x02)

Send: 01 06 00 30 00 02 08 04

01	06	00 30	00 02	08 04
System Address	Function Code	Register Address	New Address	CRC16 check digit automatically generated by software

Answer: 01 06 00 30 00 02 08 04 (indicates that the modification is successful)

Warranty and After-sales Service:

Warranty: The product warranty period is 12 months from the delivery date (except for the product problems caused by not operating in accordance with corresponding technical requirements or other artificial behavior).

After-sales telephone: 86-0731-86117089 www.codasensor.com Molly@codasensor.com

Other Weather Sensors

Model number	Type	Output	Special features
CDF-10A	Wind speed	Pulses(PNP) RS485 4-20MA 0-5V	Three cup plastic wind speed
CDF-11A	Wind direction	RS485 4-20MA 0-5V	Plastic wind direction sensor
CDW-33A	Atmospheric Temperature, Humidity & Pressure	RS485	Shelter installation
CDY-12A	Economical Tipping Bucket Rainfall	Pulses(@10kΩ&0.01uF),RS485	Diameter :φ200mm, height: 271mm
CDG-10B	Solar Radiation	0-5V,4-20mA,RS485	Spectral range:300~1100nm
CDT-11A	PH sensor	0-2V 0-5V 4-20mA RS485	Probe: Φ28*160mm
CDT-12A	DO sensor	RS485 4-20mA	Range 0-20mg/L(ppm)
CDT-12B	DO sensor(calibrable)	RS485 4-20mA	Range 0-20mg/L(ppm)
CDT-14A	ORP sensor	RS485 4-20mA	Range -1500mV-+1500mV
CDT-15A	Suspended Matter	RS485	Range 0-200mg/L,0-1000mg/L,0-5000mg/L
CDT-17B	Soil PH sensor	RS485 4-20mA	Probe material:304SS
CDT-19B	Turbidity (SS) sensor	RS485 4-20mA	Wavelength of falling radiation: 860nm
CDT-21B	Soil EC_salinity	RS485 4-20mA	Probe material:316L
CDT-22B	Soil Moisture & Temperature	4-20mA ,0-5V,0-2V,RS485 optional	Probe material:316L
CDT-30B	Soil Moisture, Temperature & EC	RS485,0-2V	316L stainless steel
CDT-70B	Soil 7 in 1 Sensor	RS485	Soil Moisture, Temperature & EC & PH & NPK
CDT-1T2B	Seismic Detection Wave	0-20mV RS485	Natural Frequency(Hz):10±2.5%
CDT-1T3B	Soil layers temperature&moisture	RS485	Range 0-100℃ 0-70%
CDT-1T4B	TDS Sensor	RS485 4-20mA	Range 0-2000ppm
CDT-1T5B	Dissolved CO2 Sensor	RS485	Range 0-2000ppm
CDT-1T6B	Residual Chlorine	RS485	Range 2mg/L,8mg/L,20mg/L
CDT-N0C	Multi-parameter water quality Sensor	RS485	Multi-parameter integration