

CDT-14A
ORP(Oxidation-Reduction Potential) Sensor
Manual

Catalogue

Product Brief.....	1
Application	1
Features	1
Technical Parameters	2
Product Size	3
Accessories:	3
MODBUS RTU Communication Protocol (Apply to CDT-14A product)	4
1.1 CRC Description:	4
1.2 Return Error Code Rule:	4
1.3 Standard MODBUS register description	4
1.4 Electrical Connections	5
1.5 Communication Example	5
Other Weather Sensors	8



CDT-14A Oxidation-Reduction Potential Sensor

◆ Product Brief

ORP sensor is simple and cost effective solution for a wide variety of waste water and process applications. This all-in-one sensor provides simultaneous measurement of ORP and temperature. The rugged Ryton body is designed for easy installation into on-line via the 3/4 inch tapered threaded connections provided on both ends of the sensor.

◆ Application

- Meteorological Monitoring
- Micro Environmental Monitoring
- Grid Environment Monitoring
- Agricultural Meteorological Monitoring
- Meteorological Traffic Monitoring
- Photovoltaic Environment Monitoring
- Meteorological Environment Monitoring for Smart Cities

◆ Features

- Small in size
- High integration
- Easy to install
- Free testing software MODBUS - poll V1.0 (ask your salesperson for it)
- Integrated design
- Low starting threshold
- One year warranty

CTDA Technical Data

CDT-14A Oxidation-Reduction Potential Sensor

◆ Technical Parameters

Parameters	Measuring Range	Accuracy	Resolution
ORP	-1999mV-+1999mV	±1mV	1mV
Temperature	0-80℃	±0.3℃	0.1℃
Operating Temperature	0℃—80℃		
Output	Standard product with RS485 interface, MODBUS RTU; 4-20mA / 0-5V / 0-10V		
Power Supply	DC10-30V		
Protection Level	IP68		
Cable Length	5m (10m 15m 20m can customize)		
Repeatability Error	±0.02		
Power Consumption	RS485 0.6W / Analog:1.2W		
Electrode Type	Conventional electrode / Glass electrode / Teflon electrode / Sulfur removal electrode		
Operating Environment	Seawater / Freshwater / Strong acids and strong bases / Organic matter water quality		
Temperature compensation	Default temperature :25℃ (can set 0-80℃)		
Controller	Power	22VAC or 10-30VDC	
	Communication	RS485	
	Output	Relay output AC220V	
	Data storage	72 pieces of data (3 Days)	
	Protection Level	IP54	
	Power Consumption	DC24V : <1.6W AC220V : <15W	

★ Specifications may be updated without prior notice.

CTDA Technical Data

CDT-14A Oxidation-Reduction Potential Sensor

◆ Product Size

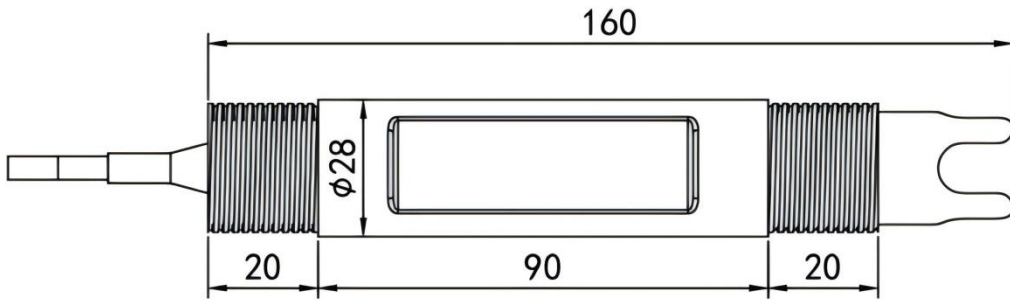

Size : 96*96*110mm Electrode thread: NPT3/4
Installation opening dimensions :92*92mm

◆ Accessories:

Mounting Manner:

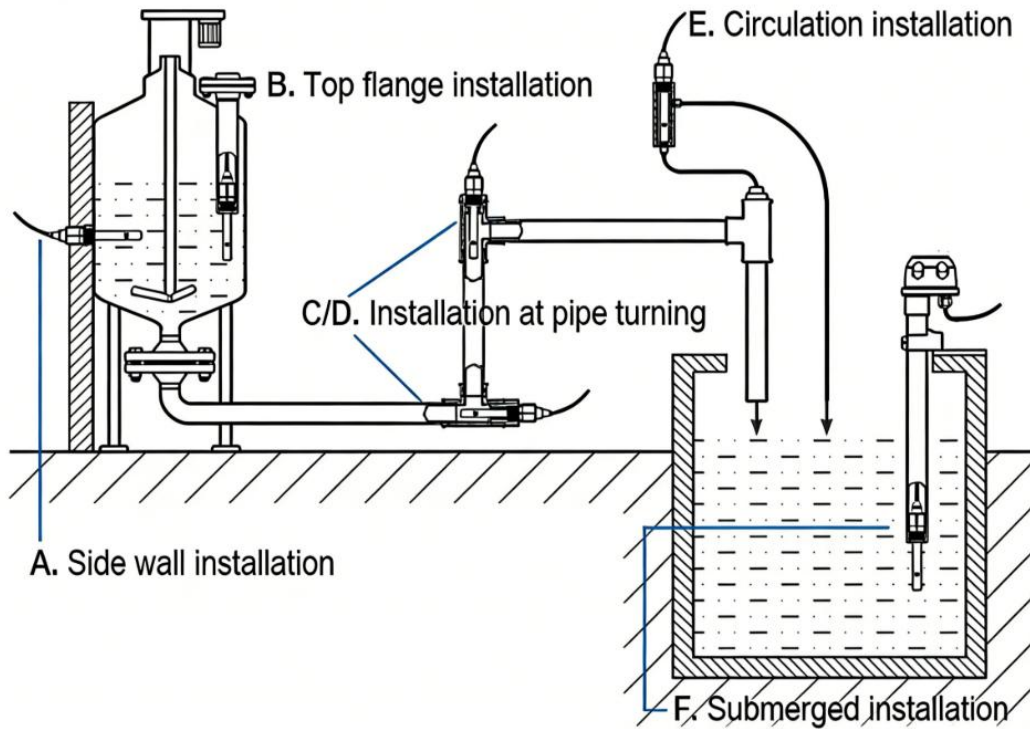

MODBUS RTU Communication Protocol

(Apply to CDT-14A product)

Baud Rate: 4800
Data Bits: 8
Stop Bit: 1
Check Bit: None

1.1 CRC Description:

Among all the following instructions, the two bytes of CRC16 in MODBUS RTU protocol are as follows: the low byte comes before and the high byte comes after.

In the following instructions, the assumed sensor address is 0x01 (the default sensor address is 01).

1.2 Return Error Code Rule:

When receive error instruction (including CRC16 validation error), no error codes will be returned. It is considered to be a failure, when there is no return data in 200ms after the instruction is issued. Upper computer may resend instruction.

1.3 Standard MODBUS register description

Special Notice:

The quantity or length of the register in MODBUS is two bytes with 16 bits as a unit (the high byte comes first, and the low bytes follows), instead of one byte with 8 bits as a unit.

User shall ensure that the address and quantity of register in command are confined within the range specified by the system. Otherwise, the output of the sensor will be unpredictable. Users shall ensure that the MODBUS command complies with the requirements of this manual in the software design of the upper computer and the minimum query period supported is 1s/ time.

Input register: read with function code 03

Address	Operation	Contents	Note
0x0000	Read-only	ORP, a hexadecimal number magnified by 1 times. For example, 0x02AD indicates 685=685mV	
0x0001	Read-only	Temperature, a hexadecimal number magnified by 10 times. For example, 0x0100 indicates 256/10=25.6°C	
0x07D0	Read/Write	Device Address(1-255)	Default address 01
0x07D1	Read/Write	0 represents 2400 1 represents 4800 2 represents 9600 3 represents 19200 4 represents 38400 5 represents 57600 6 represents 115200 7 represents 1200	Default Baud rate 4800

1.4 Electrical Connections

Connector(cable)	Voltage	Current	RS485
Pin 1(red)	V+	V+	V+
Pin 2(yellow)	V- out	I -out	RS485A
Pin 3(black/green)	V-	V-	V-
Pin 4(blue)			RS485B

1.5 Communication Example

The following is an example of how to use MODBUS RTU commands to access system registers:

1. Read multiple input registers (real time data) command

Send: 01 03 00 00 00 02 C4 0B

01	03	00 00	00 02	C4 0B
System Address	Function Code	Register Address	Number of Registers	CRC16 check digit automatically generated by software

CTDA Technical Data

CDT-14A Oxidation-Reduction Potential Sensor

Answer: 01 03 04 03 16 01 09 B8 BE

01	03	04	03 16 01 09	B8 BE
System Address	Function Code	The number of bytes in a data segment	Segment Data	CRC16 check bit

Analytical Data:

$$0x0316 = 0x03 * 256 + 0x16 = 790$$

$$ORP = 790/1 = 790\text{mV}$$

$$0x0109 = 0x01 * 256 + 0x09 = 265$$

$$\text{Temperature} = 265/10 = 26.5^\circ\text{C}$$

2. Controller menu

No.	Menu Item	Setting	Parameter Range	Default Value
1	Alarm Settings	High PH Alarm	0.00~14.00 PH	14.00 PH
		Low PH Alarm	0.00~14.00 PH	0.00 PH
		High ORP Alarm	-1999~1999 mV	1999 mV
		Low ORP Alarm	-1999~1999 mV	-1999 mV
2	Analog Output	PH Corresponding to 4~20mA Output	0.00~14.00 PH	0.00/14.00 PH
		ORP Corresponding to 4~20mA Output	-1999~1999 mV	-1999/1999 mV
3	Temperature Correction	Correction Temperature	-99.9~+99.9 °C	0.0 °C
4	Filter Coefficient	Filter Coefficient Setting(Larger value = more stable)	1~15	15
5	PH Calibration	Two-Point PH Calibration	-	-

CTDA Technical Data

CDT-14A Oxidation-Reduction Potential Sensor

No.	Menu Item	Setting	Parameter Range	Default Value
	Potential Correction	PH Offset	-20.00~20.00 PH	0.00 PH
		Coefficient Correction	0.900~1.100	1.000
		Potential Offset	-99~99 mV	0 mV
6	Temperature Compensation	Auto Temperature Compensation	-	-
		Manual Temperature Compensation	0.0~99.9 °C	25.0 °C
7	Communication Settings	MODBUS Address	0-255	001
		Baud Rate	1200/2400/4800/9600/19200 /38400/57600/115200	4800
		Parity	None/Even/Odd	None
8	Factory Settings	Restore Factory Settings	-	-
9	Current Correction	Correct 4-20mA Current Output Offset	-9.99~+9.99 mA	0.00 mA
10	History Data	Record Data of Past 3 Days (1 point/hour)	-	-
11	Measurement Mode	Display PH or ORP Value	-	PH Measurement
12	System Settings	Time Settings	-	Current Time
		Password Settings	0000-9999	0000
		Backlight Settings	0~9999 s (0 = Always On)	0
		Buzzer Settings	On/Off	Off
		Contrast Settings	0-32	5

Warranty and After-sales Service:

Warranty: The product warranty period is 12 months from the delivery date (except for the product problems caused by not operating in accordance with corresponding technical requirements or other artificial behavior).

After-sales telephone: 86-0731-86117089 www.codasensor.com Molly@codasensor.com

Other Weather Sensors

Model number	Type	Output	Special features
CDF-10A	Wind speed	Pulses(PNP) RS485 4-20MA 0-5V	Three cup plastic wind speed
CDF-11A	Wind direction	RS485 4-20MA 0-5V	Plastic wind direction sensor
CDW-33A	Atmospheric Temperature, Humidity & Pressure	RS485	Shelter installation
CDY-12A	Economical Tipping Bucket Rainfall	Pulses(@10kΩ&0.01uF),RS485	Diameter :φ200mm, height: 271mm
CDG-10B	Solar Radiation	0-5V,4-20mA,RS485	Spectral range:300~1100nm
CDT-11A	PH sensor	0-2V 0-5V 4-20mA RS485	Probe: Φ28*160mm
CDT-12A	DO sensor	RS485 4-20mA	Range 0-20mg/L(ppm)
CDT-12B	DO sensor(calibrable)	RS485 4-20mA	Range 0-20mg/L(ppm)
CDT-14A	ORP sensor	RS485 4-20mA	Range -1500mV~+1500mV
CDT-15A	Suspended Matter	RS485	Range 0-200mg/L,0-1000mg/L,0-5000mg/L
CDT-17B	Soil PH sensor	RS485 4-20mA	Probe material:304SS
CDT-19B	Turbidity (SS) sensor	RS485 4-20mA	Wavelength of falling radiation: 860nm
CDT-21B	Soil EC_salinity	RS485 4-20mA	Probe material:316L
CDT-22B	Soil Moisture & Temperature	4-20mA ,0-5V,0-2V,RS485 optional	Probe material:316L
CDT-30B	Soil Moisture, Temperature & EC	RS485,0-2V	316L stainless steel
CDT-70B	Soil 7 in 1 Sensor	RS485	Soil Moisture, Temperature & EC & PH & NPK
CDT-1T2B	Seismic Detection Wave	0-20mV RS485	Natural Frequency(Hz):10±2.5%
CDT-1T3B	Soil layers temperature&moisture	RS485	Range 0-100℃ 0-70%
CDT-1T4B	TDS Sensor	RS485 4-20mA	Range 0-2000ppm
CDT-1T5B	Dissolved CO2 Sensor	RS485	Range 0-2000ppm
CDT-1T6B	Residual Chlorine	RS485	Range 2mg/L,8mg/L,20mg/L
CDT-N0C	Multi-parameter water quality Sensor	RS485	Multi-parameter integration