

CDW-10A
Wall-mounted Barometric Pressure Sensor
Manual

Catalogue

Product Brief..... 1

Application 1

Features 1

Technical Parameters 2

Product Size 3

Accessories: 3

MODBUS RTU Communication Protocol (Apply to CDW-10A product) 4

 1.1 CRC Description: 4

 1.2 Return Error Code Rule: 4

 1.3 Standard MODBUS register description 4

 1.4 Electrical Connections 5

 1.5 Communication Example 5

Other Weather Sensors 7



CDW-10A Wall-mounted Barometric Pressure Sensor

◆ Product Brief

CDW-10A Wall-mounted Barometric Pressure Sensor with small size, reliable performance, high precision, long transmission distance, strong anti-jamming capability, which is widely used in meteorology, marine, environment, airports, ports, laboratory, agricultural and transportation and other fields.

◆ Application

- Meteorological Monitoring
- Micro Environmental Monitoring
- Grid Environment Monitoring
- Agricultural Meteorological Monitoring
- Meteorological Traffic Monitoring
- Photovoltaic Environment Monitoring
- Meteorological Environment Monitoring for Smart Cities

◆ Features

- Small in size
- High integration
- Easy to install
- Free testing software MODBUS - poll V1.0 (ask your salesperson for it)
- Integrated design
- Low starting threshold
- One year warranty

Technical Data

CDW-10A Wall-mounted Barometric Pressure Sensor

◆ Technical Parameters

Parameters	Measuring Range	Accuracy	Resolution
Barometric Pressure	600-1100hPa(mbar) or 0-1100hPa(mbar) optional	±0.5hPa	0.1hPa
Operating Temperature	-40°C—75°C		
Output	Standard product with RS485 interface, MODBUS RTU; 4-20mA / 0-5V / 0-10V		
Power Supply	DC12-24V / DC5V		
Temperature Drift	≤0.02%FS/°C		
Response time	1s		
Main material	ABS		
Dimension	117 *86*40 mm		
Display	LCD optional		
Weight(unpacked)	100g		
Protection level	IP65		
Storage Condition	10°C-60°C@20%-90%RH		

Response time

★ Specifications may be updated without prior notice.

CGDA Technical Data

CDW-10A Wall-mounted Barometric Pressure Sensor

◆ Product Size

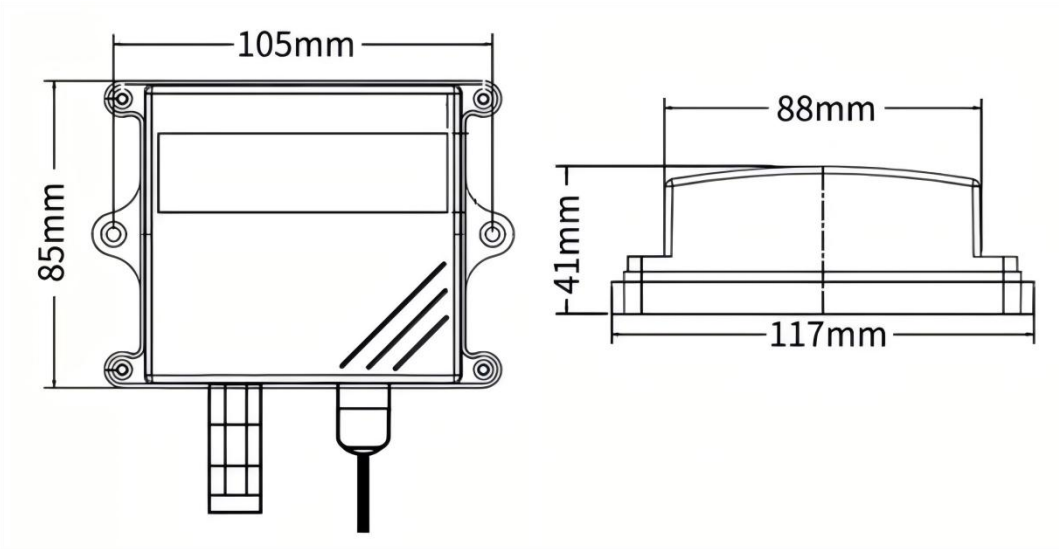

◆ Accessories:

Mounting Manner:



Multi Mode Display(LED & LCD)



MODBUS RTU Communication Protocol

(Apply to CDW-10A product)

Baud Rate: 9600
Data Bits: 8
Stop Bit: 1
Check Bit: None

1.1 CRC Description:

Among all the following instructions, the two bytes of CRC16 in MODBUS RTU protocol are as follows: the low byte comes before and the high byte comes after.

In the following instructions, the assumed sensor address is 0x01 (the default sensor address is 01).

1.2 Return Error Code Rule:

When receive error instruction (including CRC16 validation error), no error codes will be returned. It is considered to be a failure, when there is no return data in 200ms after the instruction is issued. Upper computer may resend instruction.

1.3 Standard MODBUS register description

Special Notice:

The quantity or length of the register in MODBUS is two bytes with 16 bits as a unit (the high byte comes first, and the low bytes follows), instead of one byte with 8 bits as a unit.

User shall ensure that the address and quantity of register in command are confined within the range specified by the system. Otherwise, the output of the sensor will be unpredictable. Users shall ensure that the MODBUS command complies with the requirements of this manual in the software design of the upper computer and the minimum query period supported is 1s/ time.

CGDA Technical Data

CDW-10A Wall-mounted Barometric Pressure Sensor

Input register: read with function code 03

Address	Operation	Contents	Note
0x0000	Read-only	Barometric Pressure , a hexadecimal number magnified by 100 times. For example, 0x2748 indicates 10056/100=100.56(kPa)	

1.4 Electrical Connections

Cable	Voltage/Current	RS485
Red	V+	V+
Black	V-	V-
Yellow	Out	RS485A
Green	Out	RS485B

1.5 Communication Example

The following is an example of how to use MODBUS RTU commands to access system registers:

1. Read multiple input registers (real time data) command

Send: 01 03 00 00 00 01 84 0A

01	03	00 00	00 01	84 0A
System Address	Function Code	Register Address	Number of Registers	CRC16 check digit automatically generated by software

Answer: 01 03 02 27 48 A3 82

01	03	02	27 48	A3 82
System Address	Function Code	The number of bytes in a data segment	Segment Data	CRC16 check bit

Technical Data

CDW-10A Wall-mounted Barometric Pressure Sensor

Analytical Data:

$$0x2748 = 0x27 * 256 + 0x48 = 10056$$

$$\text{Barometric Pressure} = 10056/100 = 100.56\text{kPa}$$

2. Modify internal register (system address) command (change the address to 0x02)

Send: 01 06 00 30 00 02 08 04

01	06	00 30	00 02	08 04
System Address	Function Code	Register Address	New Address	CRC16 check digit automatically generated by software

Answer: 01 06 00 30 00 02 08 04 (indicates that the modification is successful)

Warranty and After-sales Service:

Warranty: The product warranty period is 12 months from the delivery date (except for the product problems caused by not operating in accordance with corresponding technical requirements or other artificial behavior).

After-sales telephone: 86-0731-86117089 www.codasensor.com Molly@codasensor.com

Other Weather Sensors

Model number	Type	Output	Special features
CDF-10A	Wind speed	Pulses(PNP) RS485 4-20MA 0-5V	Three cup plastic wind speed
CDF-11A	Wind direction	RS485 4-20MA 0-5V	Plastic wind direction sensor
CDG-10B	Solar radiation	0-5V,4-20mA,RS485	Spectral range:300~1100nm
CDG-14A	Illuminance sensor	0-5V 0-10V 4-20mA RS485	Spectral range:380~780nm
CDY-12A	Economical Tipping Bucket Rainfall	Pulses(@10kΩ&0.01uF),RS485	Diameter :φ200mm, height: 271mm
CDW-10A	Wall-mounted Barometric Pressure	RS485,4-20mA,0-5V, 0-10V	Barometric range 600-1100hPa(mbar)
CDW-12A	CO2 sensor	4-20mA,0-5V,RS485	Range 0-5000ppm,0-10000ppm
CDW-13B	Noise sensor	RS485	Range 30-130dB
CDW-14A	Paste Type Temperature	PT100 PT1000 RS485	Range -50-+100℃, -20-+50℃
CDW-21A	Dust sensor	RS485 4-20mA,0-5V,0-10V	PM1.0,PM2.5,PM10
CDW-22A	Leaf Wetness	4-20mA,0-5V,0-2V,RS485	Wetness: 0-100% Temperature: -40-+80℃
CDW-33A	Atmospheric Temperature, Humidity & Pressure	RS485	Shelter installation
CDW-15A	O2 Concentration	4-20mA,0-5V,0-10V,RS485	Range 0-30%
CDW-16A	SO2 Concentration	4-20mA,0-5V,0-10V,RS485	Range 0-20PPM 0-2000PPM
CDW-17A	NH3 Concentration	4-20mA,0-5V,0-10V,RS485	Range 0-100PPM 0-1000PPM 0-5000PPM
CDW-18A	H2S Concentration	4-20mA,0-5V,0-10V,RS485	Range 0-100PPM 0-1000PPM
CDW-19A	CO Concentration	4-20mA,0-5V,0-10V,RS485	Range 0-1000PPM 0-2000PPM
CDW-1T0	Visibility sensor	RS485	Range 0-10Km/0-20Km/0-30Km
CDW-1TX	Multi-in-one gas Sensor	RS485	Multi-parameter integration