

CDG-17B
Scattering Radiometer Sensor
Manual

Catalogue

Product Brief.....	1
Application	1
Features	1
Technical Parameters	2
Product Size	3
Accessories:	4
MODBUS RTU Communication Protocol (Apply to CDG-17B product)	5
1.1 CRC Description:	5
1.2 Return Error Code Rule:	5
1.3 Standard MODBUS register description	5
1.4 Electrical Connections	6
1.5 Communication Example	6
Other Weather Sensors	8



CDG-17B Scattering Radiometer Sensor

◆ **Product Brief**

Scattering radiometer is composed of Pyranometer and shielding ring. The purpose of a shielding ring is to keep the sun's direct radiation out from sunrise to sunset. The shielding ring is composed of shielding ring, ruler, adjusting screw, bracket and chassis. The width of the shielding ring is 65mm and the diameter is 400mm. The shielding ring is fixed on the screw rod adjustment spiral of the ruler, on which the latitude scale and declination scale are engraved.

◆ **Application**

- Meteorological Monitoring
- Micro Environmental Monitoring
- Agricultural Meteorological Monitoring
- Meteorological Traffic Monitoring
- Photovoltaic Environment Monitoring
- Meteorological Environment Monitoring for Smart Cities

◆ **Features**

- Small in size
- High integration
- Easy to install
- Free testing software MODBUS - poll V1.0 (ask your salesperson for it)
- Integrated design
- Low starting threshold
- One year warranty

♦ **Technical Parameters**

Parameters	Measuring Range	Accuracy	Resolution
Scattering	0-2000W/m ²	≤±2%	1W/m ²
Operating Temperature	-40°C—80°C		
Output	Standard product with RS485 interface, MODBUS RTU; 4-20mA / 0-5V		
Power Supply	DC12-24V		
Spectral range	280~3000nm		
Cosine correction	≤±7%(Solar elevation angle=10°)		
Weight(unpacked)	15kg		
Dimension	Ø410mm*565mm		
Stability	≤±1%/year		
Temperature effect	±1%(-10°C+40°C)		
Main material	Aluminum alloy		
Sensitivity	7-14μV*W-1*m ²		
Protection level	IP65		
Storage Condition	10°C-60°C@20%-90%RH		
Latitude scale range	0~50° N or S		
Red latitude	±25°		
Ring diameter	Φ400mm		

Response time

★ Specifications may be updated without prior notice.

◆ **Product Size**

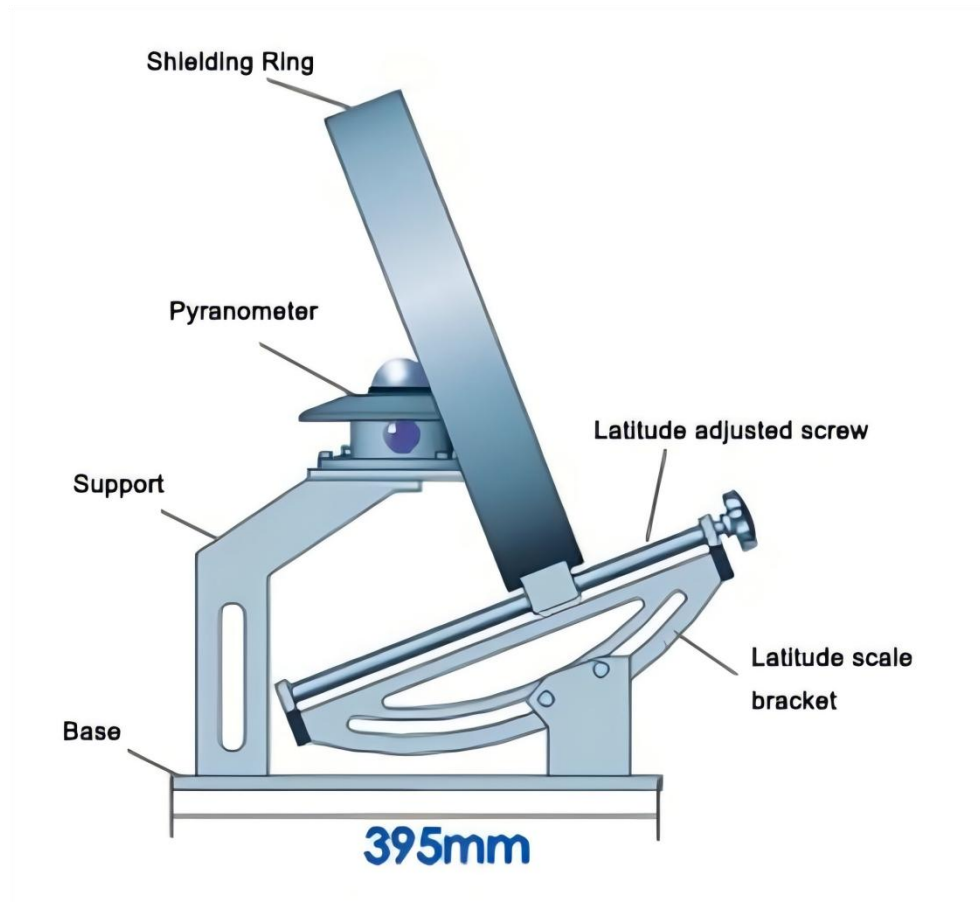
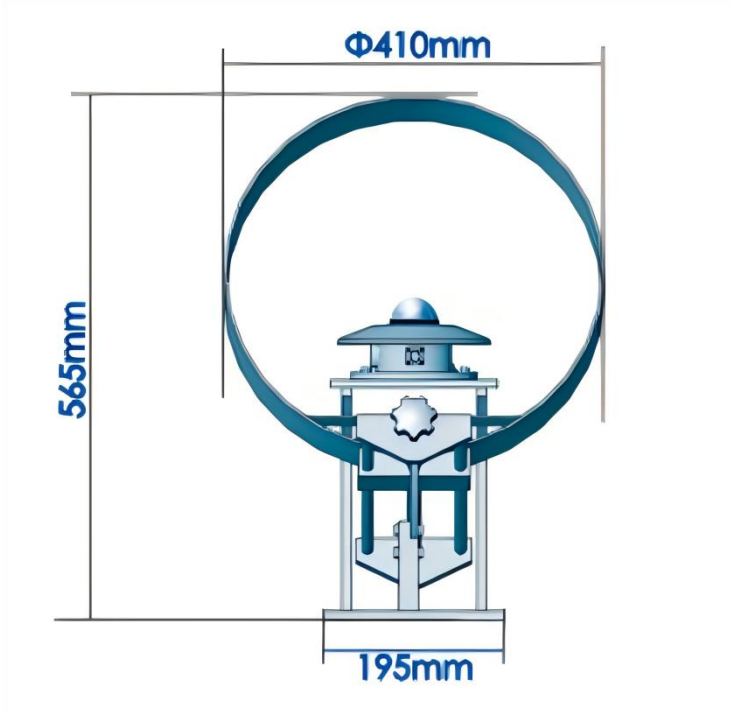

CSDA Technical Data

CDG-17B Scattering Radiometer Sensor

- ◆ **Accessories:**
Mounting Manner:



MODBUS RTU Communication Protocol

(Apply to CDG-17B product)

Baud Rate: 9600
Data Bits: 8
Stop Bit: 1
Check Bit: None

1.1 CRC Description:

Among all the following instructions, the two bytes of CRC16 in MODBUS RTU protocol are as follows: the low byte comes before and the high byte comes after.

In the following instructions, the assumed sensor address is 0x01 (the default sensor address is 01).

1.2 Return Error Code Rule:

When receive error instruction (including CRC16 validation error), no error codes will be returned. It is considered to be a failure, when there is no return data in 200ms after the instruction is issued. Upper computer may resend instruction.

1.3 Standard MODBUS register description

Special Notice:

The quantity or length of the register in MODBUS is two bytes with 16 bits as a unit (the high byte comes first, and the low bytes follows), instead of one byte with 8 bits as a unit.

User shall ensure that the address and quantity of register in command are confined within the range specified by the system. Otherwise, the output of the sensor will be unpredictable. Users shall ensure that the MODBUS command complies with the requirements of this manual in the software design of the upper computer and the minimum query period supported is 1s/ time.

Input register: read with function code 03

Address	Operation	Contents	Note
0x0000	Read-only	Scattering Radiation , a hexadecimal number magnified by 1 times. For example, 0x03B4 indicates 948/1=948W/m2	

1.4 Electrical Connections

Cable	Voltage	Current	RS485
Red	V+	V+	V+
Black	V-	V-	V-
Yellow	V-out	I-out	RS485A
Blue/Green			RS485B

1.5 Communication Example

The following is an example of how to use MODBUS RTU commands to access system registers:

1. Read multiple input registers (real time data) command

Send: 01 03 00 00 00 01 84 0A

01	03	00 00	00 01	84 0A
System Address	Function Code	Register Address	Number of Registers	CRC16 check digit automatically generated by software

Answer: 01 03 02 03 B4 91 E7

01	03	02	03 B4	91 E7
System Address	Function Code	The number of bytes in a data segment	Segment Data	CRC16 check bit

Technical Data

CDG-17B Scattering Radiometer Sensor

Analytical Data:

$$0x03B4 = 0x03 * 256 + 0xB4 = 948$$

$$\text{Scattering Radiation} = 948/1 = 948 \text{ W/m}^2$$

2. Modify internal register (system address) command (change the address to 0x02)

Send: 01 06 01 00 02 09 F7

01	06	00 01	00 02	09 F7
System Address	Function Code	Register Address	New Address	CRC16 check digit automatically generated by software

Answer: 01 06 01 00 02 09 F7 (indicates that the modification is successful)

Warranty and After-sales Service:

Warranty: The product warranty period is 12 months from the delivery date (except for the product problems caused by not operating in accordance with corresponding technical requirements or other artificial behavior).

After-sales telephone: 86-0731-86117089 www.codasensor.com Molly@codasensor.com

Other Weather Sensors

Model number	Type	Output	Special features
CDF-10A	Wind speed	Pulses(PNP) RS485 4-20MA 0-5V	Three cup plastic wind speed
CDF-11A	Wind direction	RS485 4-20MA 0-5V	Plastic wind direction sensor
CDF-20B	Combined Wind Speed & Direction	RS485 4-20MA 0-5V 0-10V	Integrated wind speed and direction
CDF-21A	Ultrasonic Wind Speed & Direction	RS232/RS485(Modbus/NMEA-0183), Voltage(0-5V),Current(4-20mA) optional	Ultrasonic principle
CDW-33A	Atmospheric Temperature, Humidity & Pressure	RS485	Shelter installation
CDQ-T6A	Miniature Ultrasonic Automatic Weather	RS485	Wind speed & direction temp & humidity & pressure
CDY-12A	Economical Tipping Bucket Rainfall	Pulses(@10kΩ&0.01uF),RS485	Diameter :φ200mm, height: 271mm
CDG-10B	Solar Radiation	0-5V,4-20mA,RS485	Spectral range:300~1100nm
CDG-11B	Pyranometer	0-20mV,RS485	Spectral range:300~3000nm Class one
CDG-12B	PAR sensor	0-5V 4-20mA RS485	Spectral range:400~700nm
CDG-13B	Ultraviolet(UV) Radiation	0-5V 0-10V 4-20mA RS485	Spectral range:280~400nm
CDG-14A	Illuminance Sensor	0-5V 0-10V 4-20mA RS485	Spectral range:380~780nm
CDG-17B	Scattering Radiometer	RS485	Spectral range:280~3000nm