

CDF-21A  
Ultrasonic Wind Speed  
And Wind Direction Sensor  
  
Manual

## Catalogue

Product Brief.....	1
Application .....	1
Features .....	1
Technical Parameters .....	2
Product Size .....	3
Accessories: .....	4
MODBUS RTU Communication Protocol (Apply to CDF-21A product) .....	5
1.1 CRC Description: .....	5
1.2 Return Error Code Rule: .....	5
1.3 Standard MODBUS register description .....	5
1.4 Electrical Connections .....	6
1.5 Communication Example .....	6
SDI-12 Communication Protocol .....	8
Other Weather Sensors .....	10



## CDF-21A Ultrasonic Wind Speed And Wind Direction Sensor

### ◆ Product Brief

CDF-21A Economical Ultrasonic Wind Sensor is a fully digital detector, high-precision sensors, integrated by the ultrasonic wind speed and direction sensors. it can accurately and quickly detect the wind speed, wind direction; built-in signal processing unit can output a corresponding signal in response to user needs, with the structure lightweight and compact, no moving parts, high-strength structural design can be accurately detected in the harsh climatic conditions, made the accurate and stable elements, low maintenance, an open communications protocol and so on.

### ◆ Application

- Meteorological Monitoring
- Micro Environmental Monitoring
- Grid Environment Monitoring
- Agricultural Meteorological Monitoring
- Meteorological Traffic Monitoring
- Photovoltaic Environment Monitoring
- Meteorological Environment Monitoring for Smart Cities

### ◆ Features

- Small in size
- High integration
- Easy to install
- Free testing software MODBUS - poll V1.0 (ask your salesperson for it )
- Integrated design
- Low starting threshold
- One year warranty

# Technical Data

CDF-21A Ultrasonic Wind Speed And Wind Direction Sensor

## ◆ Technical Parameters

Parameters	Measuring Range	Accuracy	Resolution
Wind Speed	0-60m/s 0-75m/s	$\leq 10\text{m/s}$ : $\pm 0.2\text{m/s}$ $> 10\text{m/s}$ : $< \pm 2\%$ the current value	0.1m/s
Wind Direction	0-360°	$\pm 3^\circ$	0.1°
Operating Temperature	-30°C—70°C		
Output	Standard product with RS485 interface, MODBUS RTU; NMEA-0183 / SDI-12		
Power Supply	DC12-24V		
Protection Level	IP66		
Extreme Wind Speed	75m/s		
Power consumption	$< 1\text{W}$ (Heating not activated); $< 3\text{W}$ (Heating activated)		
Dimension	$\Phi 144*148\text{mm}$		
Starting Threshold	$< 0.1\text{m/s}$		
Response Time	$< 1\text{s}$		
Main material	ABA		
Heating power	Automatically turn on when the ambient temperature is below 0°C		
Weight(unpacked)	0.8kg		
Electronic compass	optional		
Atmospheric pressure	optional		

★ Specifications may be updated without prior notice.

◆ **Product Size**

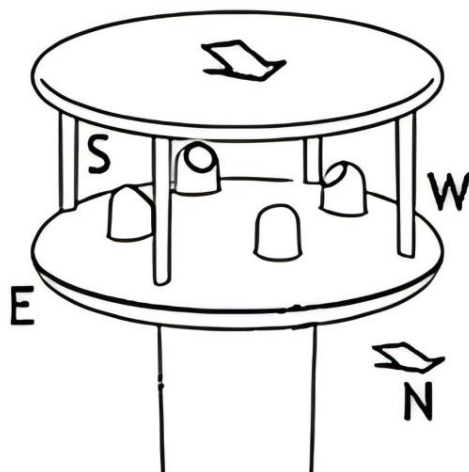
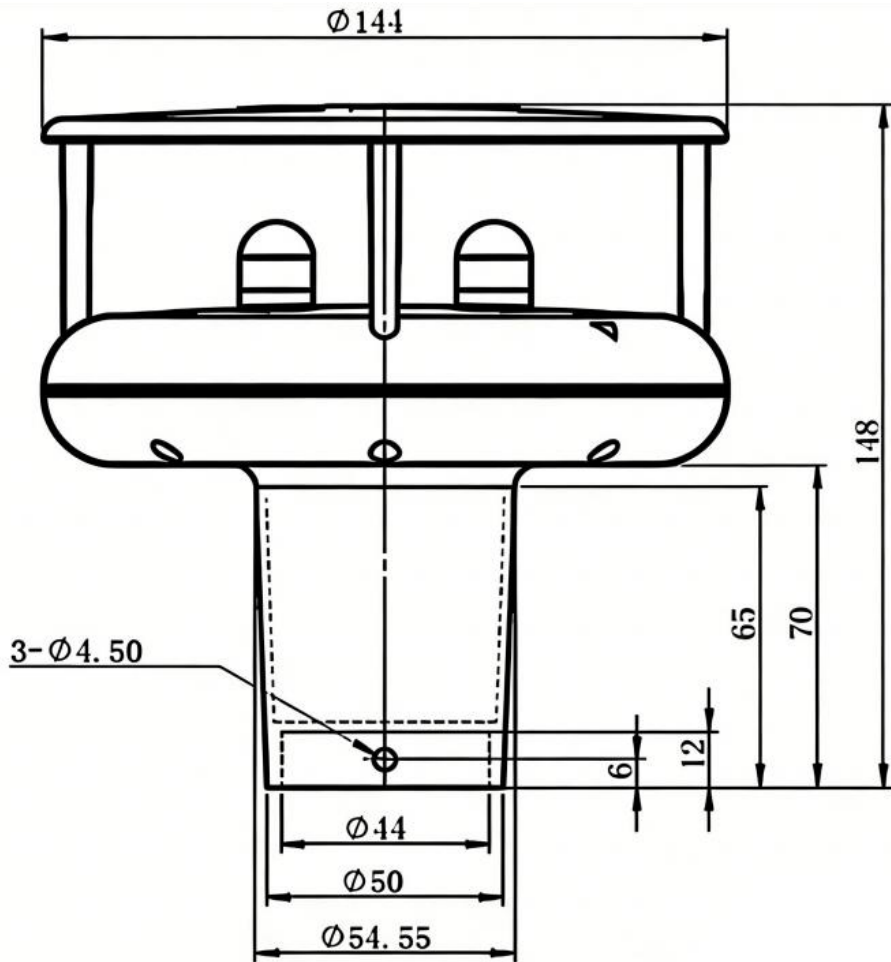

# CSDA Technical Data

CDF-21A Ultrasonic Wind Speed And Wind Direction Sensor

- ◆ **Accessories:**  
Mounting Manner:

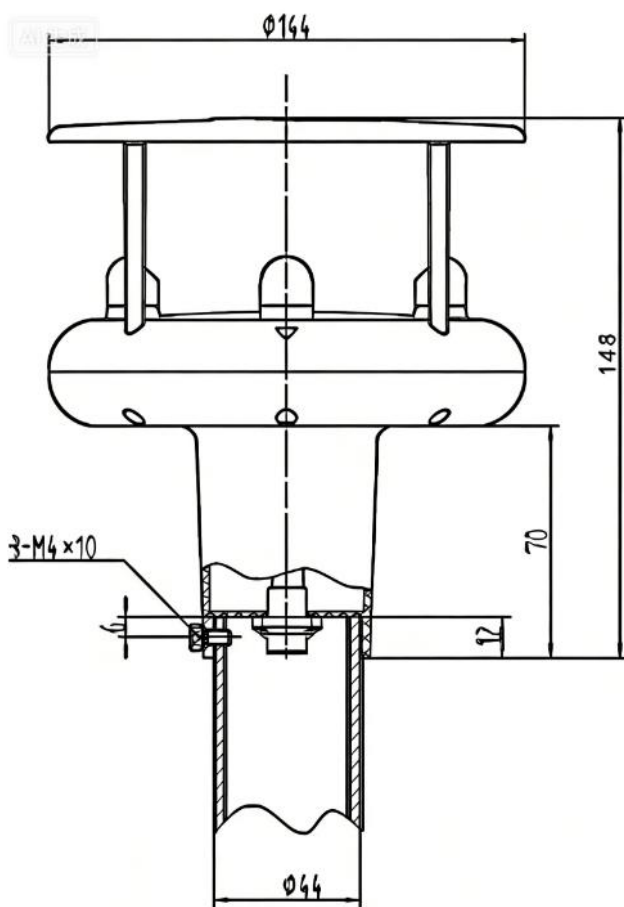

# MODBUS RTU Communication Protocol

## (Apply to CDF-21A product)

Baud Rate: 9600  
Data Bits: 8  
Stop Bit: 1  
Check Bit: Even

### 1.1 CRC Description:

Among all the following instructions, the two bytes of CRC16 in MODBUS RTU protocol are as follows: the low byte comes before and the high byte comes after.

In the following instructions, the assumed sensor address is 0x01 (the default sensor address is 01).

### 1.2 Return Error Code Rule:

When receive error instruction (including CRC16 validation error), no error codes will be returned. It is considered to be a failure, when there is no return data in 200ms after the instruction is issued. Upper computer may resend instruction.

### 1.3 Standard MODBUS register description

Special Notice:

The quantity or length of the register in MODBUS is two bytes with 16 bits as a unit (the high byte comes first, and the low bytes follows), instead of one byte with 8 bits as a unit.

User shall ensure that the address and quantity of register in command are confined within the range specified by the system. Otherwise, the output of the sensor will be unpredictable. Users shall ensure that the MODBUS command complies with the requirements of this manual in the software design of the upper computer and the minimum query period supported is 1s/ time.

**Input register: read with function code 03**

Address	Operation	Contents	Note
0x0000	Read-only	Default status bit, with the value of 0x0002	
0x0001	Read-only	Wind Direction, a hexadecimal number magnified by 1 times. For example, 0x000E indicates $14=14/1=14^\circ$	
0x0002 0x0003	Read-only	Wind Speed, a hexadecimal number magnified by 16-bit floating-point number For example, 0x36F0 0x4089 indicates 4.28m/s	

**1.4 Electrical Connections**

Connector(cable)	RS485
Pin 1(red)	V+
Pin 2(yellow)	RS485A
Pin 3(black)	V-
Pin 4(blue/green)	RS485B

**1.5 Communication Example**

The following is an example of how to use MODBUS RTU commands to access system registers:

1. Read multiple input registers (real time data) command

Send: 01 03 00 00 00 04 44 09

01	03	00 00	00 04	44 09
System Address	Function Code	Register Address	Number of Registers	CRC16 check digit automatically generated by software

# CUDA Technical Data

CDF-21A Ultrasonic Wind Speed And Wind Direction Sensor

Answer: 01 03 08 00 02 00 0E 36 F0 40 89 20 0B

01	03	08	00 02	00 0E	36 F0 40 89	20 0B
System Address	Function Code	The number of bytes	Fixed value	Wind Direction Data	Wind Speed Data	CRC16 check bit

Analytical Data:

$$0x000E = 0x00 * 256 + 0x0E = 14$$

$$\text{Wind Direction} = 14/1 = 14^\circ$$

$$0x36F0 \ 0x4089 \ (\text{floating-point number}) = 4.28$$

$$\text{Wind Speed} = 4.28\text{m/s}$$

## 2. Modify internal register (system address) command

### 2.1 Command one: Enter the Settings mode

Sent

(ASCII) >\*\r\n

(Hex) 3E 2A 0D 0A

Response

(ASCII) \n>CONFIGURE MODE\r\n

(Hex) 0A 3E 43 4F 4E 46 49 47 55 52 45 20 4D 4F 44 45 0D 0A

### 2.2 Command two: Set the address

Sent

(ASCII) >CUS 9600 8-N-1\r\n

(Hex) 3E 43 55 53 20 39 36 30 30 20 38 2D 4E 2D 31 0D 0A

Response

(ASCII) >CMD IS SET\r\n

(Hex) 3E 43 4D 44 20 49 53 20 53 45 54 0D 0A

Note: This 2 is the address you want to set(set according to the need,1-255), which must be in decimal format, If 'ID' is not followed by address, the command becomes the current query address(Such as sent: >ID\r\n, Response: ID(HEX) : 02\r\n)

### 2.3 Command three: Manually exit the Settings mode

Sent

(ASCII) >!\r\n

(Hex) 3E 21 0D 0A

Response

(ASCII) \n>NORMAL MODE\r\n

After setting, power off and restart.

## SDI-12 Communication Protocol

①:” a” ,” b” is the sensor address.

Note: Band rate: 1200, Start bit:1,Data bits:7,Check bit: EVEN, Stop bit:1,sensor address: factory default 0

No.	Command	Sensor return	Command name
1	?!	0!	Read sensor address
2	a!	014HONGYUV 1000002.3000	Distinguish sensor
3	aAb!	b!	Change the address, Change address a to b
4	aM!	00015	Start measuring wind speed and direction

# CSDA Technical Data

CDF-21A Ultrasonic Wind Speed And Wind Direction Sensor

5	aD0!	0+078+03.40+ reserve+ reserve+ 1100	<p>The value status indicates the validity of the data items in order from left to right</p> <p><b>0- invalid, 1- valid</b></p> <p><b>1-Wind direction:78°, valid</b></p> <p><b>1-Wind speed:3.4m/s, valid</b></p> <p><b>0- reserve, invalid</b></p> <p><b>0- reserve, invalid</b></p>
6	aM2!	00013<CR><LF>	Start measuring atmospheric pressure
7	aD0!	0+0929.0+0000050.3+11<CR><LF>	Address+pressure+Altitude
8	aM3!	00013<CR><LF>	Start measuring Electronic compass angle
9	aD0!	0+012+11<CR><LF>	Address+ Electronic compass angle

## Warranty and After-sales Service:

Warranty: The product warranty period is 12 months from the delivery date (except for the product problems caused by not operating in accordance with corresponding technical requirements or other artificial behavior).

After-sales telephone: 86-0731-86117089 [www.codasensor.com](http://www.codasensor.com) Molly@codasensor.com

## Other Weather Sensors

Model number	Type	Output	Special features
CDF-10A	Wind speed	Pulses(PNP) RS485 4-20MA 0-5V	Three cup plastic wind speed
CDF-11A	Wind direction	RS485 4-20MA 0-5V	Plastic wind direction sensor
CDF-12A	Pipe wind speed	RS485 4-20MA 0-5V 0-10V	Duct type wind speed sensor
CDF-13B	Wind speed display controller	LED display	Wireless output relay output
CDF-15A	Digital Anemometer	LCD display	Hand-held anemometer
CDF-20B	Combined Wind Speed & Direction	RS485 4-20MA 0-5V 0-10V	Integrated wind speed and direction
CDF-21A	Ultrasonic Wind Speed & Direction	RS232/RS485(Modbus/NMEA-0183), Voltage(0-5V),Current(4-20mA) optional	Ultrasonic principle
CDF-22A	Mini Ultrasonic Wind Speed & Direction	4-20mA,RS232/RS485(Modbus or NMEA-183), SDI-12	Ultrasonic principle
CDF-26B	Recorder station for wind	LCD display & 4G WIFI Ethernet	Wind speed & direction recorder
CDQ-T6A	Miniature Ultrasonic Automatic Weather	RS485	Wind speed & direction temp & humidity & pressure
CDW-33A	Atmospheric Temperature, Humidity & Pressure	RS485	Shelter installation
CDY-12A	Economical Tipping Bucket Rainfall	Pulses(@10kΩ&0.01uF),RS485	Diameter :φ200mm, height: 271mm
CDG-10B	Solar Radiation	0-5V,4-20mA,RS485	Spectral range:300~1100nm